

Voorzetlagers Paliers à courroie

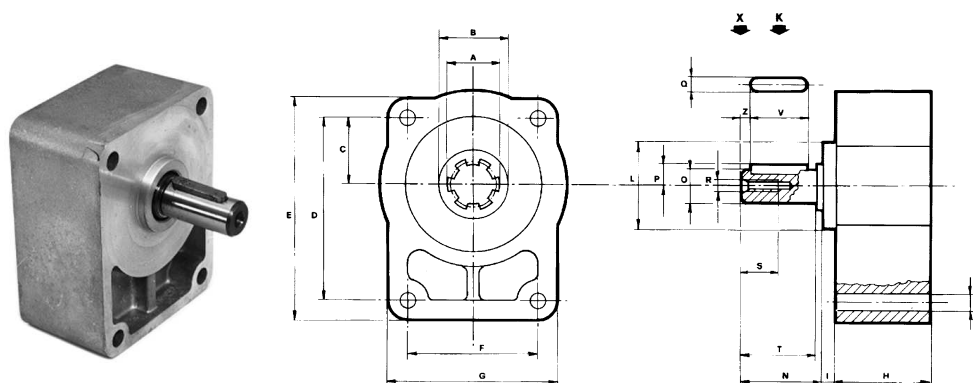

| Groep / Groupe | A | B H7 | C | D | E | F | G | H | I | L F7 | M | N | O H7 | P | Q | R | S | T | V |
|----------------|-------|---------|------|-----|-----|------|-------|----|---|---------|----|------|---------|------|---|----|----|----|----|
| 1 | 25x22 | 25,4 | 26,5 | 72 | 92 | 53 | 73 | 40 | 6 | 25,4 | 7 | 36 | 18 | 11,5 | 6 | M6 | 19 | 35 | 25 |
| 2 Stand. | 25x22 | 36,5 | 32,5 | 96 | 114 | 71,4 | 89,4 | 55 | 6 | 36,5 | 9 | 40,5 | 18 | 11,5 | 6 | M8 | 19 | 40 | 40 |
| 2 Spec. | 28x25 | 36,5 | 32,5 | 96 | 114 | 71,4 | 89,4 | 55 | 4 | 50,8 | 9 | 49,5 | 22 | 13,5 | 6 | M8 | 19 | 48 | 40 |
| 3 | 35x31 | 50,8 | 42,5 | 128 | 150 | 98,4 | 120,4 | 52 | 4 | 50,8 | 11 | 49,5 | 24 | 15 | 8 | M8 | 19 | 48 | 40 |

Voorzetlager / Palier

| Groep / Groupe | As belasting / Couple axe daN | K daN | X daN | Koppelbus / Manchon | | Ref.Lager/ Palier |
|----------------|----------------------------------|----------|----------|---------------------|------|-------------------|
| | | | | Profil | Ref. | |
| 1 | 90 | 100 | 75 | 25 x 22 | | |
| 2 Stand. | 110 | 170 | 130 | 25 x 22 | | |
| 2 Spec. | 113 | 285 | 220 | 28 x 25 | | |
| 3 | 140 | 315 | 240 | 35 x 31 | | |

Koppelbus / Manchon DIN 5482 B

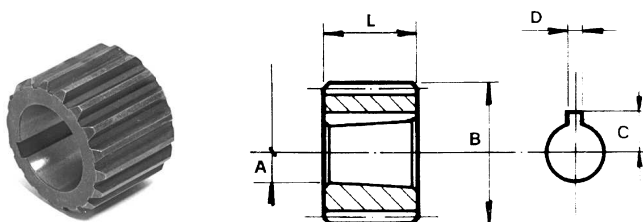

| Pompengroep | Tandprofiel | Aantal Tandem | A | B | C | D | L | Best. Nr. |
|-------------|-------------|---------------|------|------|------|------|------|-----------|
| 1 | 25x22 | 14 | 8 | 24.5 | 5.7 | 2.4 | 14.5 | |
| 2 | 25x22 | 14 | 14.2 | 24.5 | 9.7 | 3.17 | 22.0 | |
| 2 | 28x25 | 15 | 14.2 | 27.5 | 9.7 | 3.17 | 22.0 | |
| 2 | 35x31 | 18 | 14.2 | 34.5 | 9.7 | 3.17 | 22.0 | |
| 2 | 40x36 | 20 | 14.2 | 39.5 | 9.7 | 3.17 | 22.0 | |
| 3 | 35x31 | 18 | 18.7 | 34.5 | 12.5 | 4.0 | 26.0 | |
| 3 | 40x36 | 20 | 18.7 | 39.5 | 12.5 | 4.0 | 26.0 | |
| 3 | 48x44 | 23 | 18.7 | 47.5 | 12.5 | 4.0 | 26.0 | |